



AIR PRESSURE SENSING SWITCH WITH FIXED SET POINT RANGE

APPLICATION

Model DFS-301 is an airflow proving switch designed for duct heater, oven, and other HVAC or Energy Management applications where an open-mounted, nonadjustable switch is desirable. It is especially suitable for surface-mounting in areas where internal access is limited. It can be used to sense positive, negative, or differential air pressure.

GENERAL DESCRIPTION & OPERATION

The plated housing contains a diaphragm and a snap-acting **SPDT** switch. The sample line connections located on each side of the diaphragm accept $\frac{1}{4}$ " OD metallic tubing via the integral compression ferrule and nut. The electrical connection consists of male $\frac{1}{4}$ -inch quick connect terminals.

The SPDT snap action switch operates on pressure rise of 0.03 "w.c., ± 0.02 " w.c. For additional application and technical information, please contact the sales office.

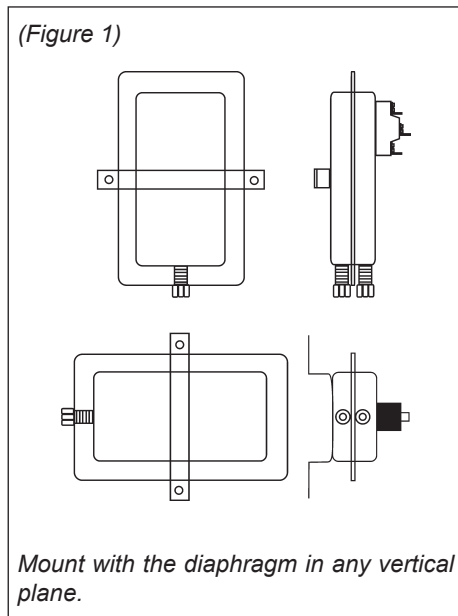
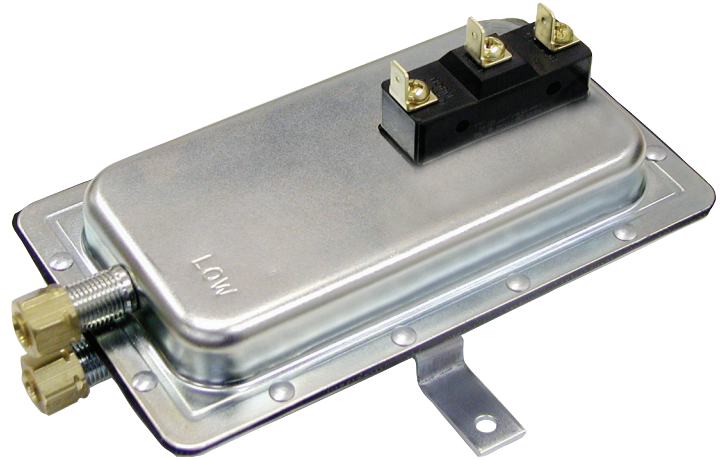

MOUNTING (FIGURE 1)

Select a mounting location which is free from vibration. The DFS-301 must be mounted with the diaphragm in any vertical plane in order to maintain the specified operating set point. Avoid mounting with the sample line connections in the "up" position. Surface mount via the two $\frac{3}{16}$ " diameter holes on the zinc-plated strap bracket. The mounting holes are $3\text{-}7/8$ " apart.

AIR SAMPLING CONNECTION (FIGURE 2)

The **DFS-301** is designed to accept firm-wall sample lines of $\frac{1}{4}$ " OD tubing by means of ferrule and nut compression connections. For sample lines of up to 10 feet, $\frac{1}{4}$ " OD tubing is acceptable. For lines up to 20 feet, use $\frac{1}{4}$ " ID tubing. For lines up to 60 feet, use $\frac{1}{2}$ " ID tubing. A $\frac{1}{4}$ " OD adapter, suitable for slip-on flexible tubing is available: order part number 18311.

Locate the sampling probe a minimum of 1.5 duct diameters downstream from the air source. Install the sampling probe as close to the center of the airstream as possible. Refer to Figure 2 to identify the high pressure inlet (H) and the low pressure inlet (L). Select one of the five application options listed below, and connect the sample lines as recommended.

POSITIVE PRESSURE ONLY: Connect the sample line to inlet H; inlet L remains open to the atmosphere.

NEGATIVE PRESSURE ONLY: Connect the sample line to inlet L; inlet H remains open to the atmosphere.

TWO NEGATIVE SAMPLES: Connect the higher negative sample to inlet L. Connect the lower negative sample to inlet H.

TWO POSITIVE SAMPLES: Connect the higher positive sample to inlet H. Connect the lower positive sample to inlet L.

ONE POSITIVE AND ONE NEGATIVE SAMPLE: Connect the positive sample to inlet H. Connect the negative sample to inlet L.

(Figure 2)

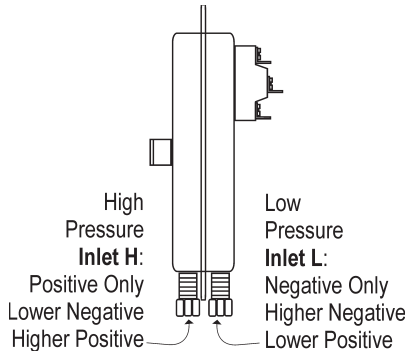

(Figure 3)

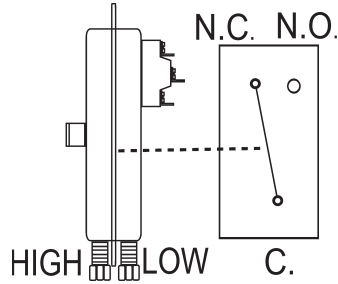

ELECTRICAL CONNECTIONS (FIGURES 3 & 4)

Before pressure is applied to the diaphragm, the switch contacts will be in the normally closed (NC) position. Control and alarm functions are wired as shown in Figure 4.

(Figure 4)

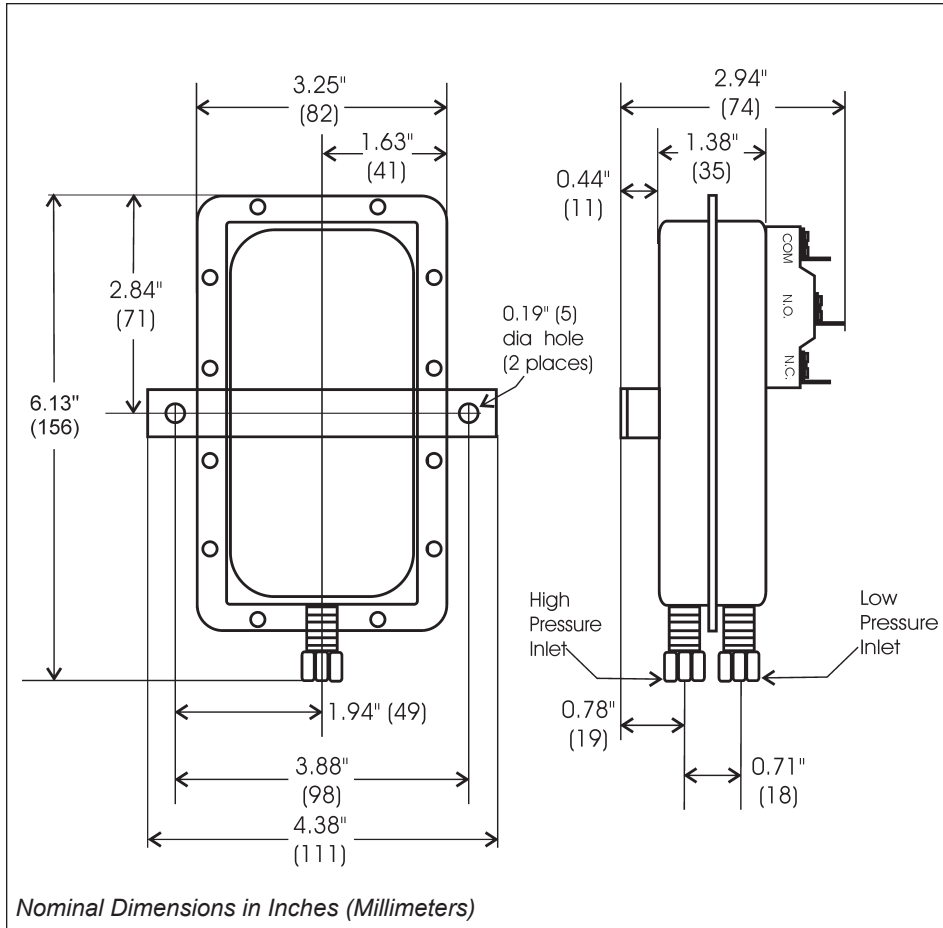
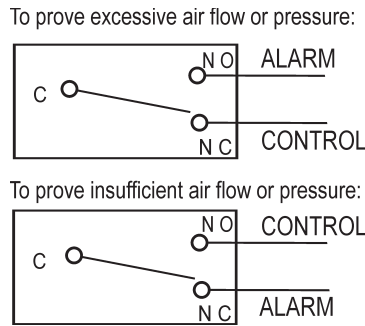

SPECIFICATIONS

CLEVELAND CONTROLS MODEL DFS-301 AIR PRESSURE SENSING SWITCH WITH FIXED SET POINT

Mounting Position: Mount with the diaphragm in any vertical plane to obtain specified operating set point.

Set Point: Fixed to operate on pressure rise at 0.03 ± 0.02 "w.c. (0.762 ± 0.508 mm).

Approximate Switching Differential:
 0.02 ± 0.01 "w.c.
(0.5082 ± 0.254 mm w.c.)

Measured Media: Air, or combustion by-products that will not degrade silicone.

Maximum Pressure: $\frac{1}{2}$ psi (0.03 bar).

Operating Temperature Range:
-40F to 180F (-40 to 82C).

Life: 100,000 cycles minimum at $\frac{1}{2}$ psi maximum pressure each cycle and at maximum rated electrical load.

Electrical Rating:

300 VA pilot duty at 115 to 277 VAC, 15 amps noninductive to 277 VAC, 60 Hz.

Contact Arrangement: SPDT.

Electrical Connections: Male $\frac{1}{4}$ " 90° "quick-connect" spade terminals.

Sample Line Connectors:

Male, externally threaded 7/16", 24 UNS 2A thread, complete with nuts and self-aligning ferrules.

Sample Line Connections:

Connectors will accept $\frac{1}{4}$ " OD rigid or semi-rigid tubing.

Approval: UL, FM, CSA.

Shipping Weight: 1.2 lbs.

Accessories

- P/N 18311 Slip-on $\frac{1}{4}$ " OD Tubing Adapter, suitable for slipping on flexible plastic tubing.
- Sample line probes.
- Orifice plugs (pulsation dampers).